

EP-MPM Explorer Accessories

Safe Connection for Motor Control Centers

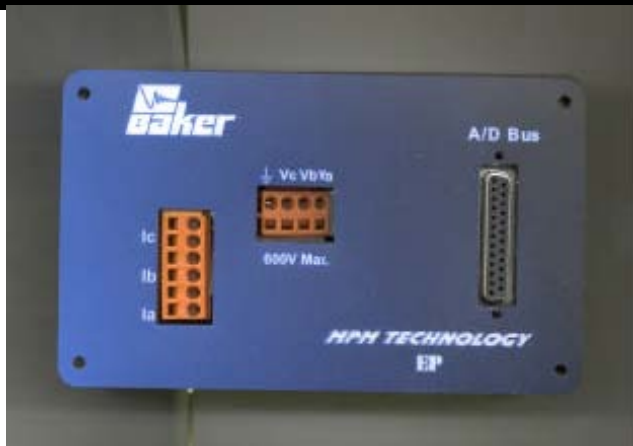

Specifications

EP Box:

External non-conductive

Size 5.5" x 3.75" x 2.25"

Weight 0.2 lbs

of Ports -3 (Voltage Input Port (VIP), Current Input Port (CIP), Mixed Signal Output Port (MSOP)).

Type of Ports: VIP: 4 pin Wago, 3 voltages to 600V and 1 GND, CIP: 6 pin Wago for 3 bi-directional CT +/-5VAC signal, MSOP: DB 25.

Current Transformers

Ratings: Primary: Amps rate for application Secondary: Voltage output rate at max +/-3 VAC peak instantaneous

Isolation: 2000V HiPot tested

Signal Bus : 6ft twisted wire. Differential signal.

EP-MCC-Cable

Length: 18 inches

Installation: From EP box to MCC front panel. Internal to MCC

Ports: DB 25 to 37 pin panel mount cannon plug connector

Pins: (7 pins) DIOS (0-5Vdc)
(6 pins) analog single ended (+/-5 VAC instan)
(3 pins) power plus ground (+/-5 Vdc)

One Explorer-EP cable pre Explorer required for EP

Features

Safety:

- Opening of MCC after installation not required for testing
- Long term data acquisition possible
- Only high impedance port (0V) external to MCC when explorer not connected
- Only voltages less than 5V peak during operation with explorer
- Fused
- Multiple Isolation levels
- Purely passive device when Explorer not connected
- CT Output: Voltage (no danger to operator with open or short circuit)

Ease of Use: operations.

- Only one low voltage bus connection required
- Only one step data acquisition
- Safe electrical on-line testing within 40 seconds without interruption of motor operation

Consistent Results

- No Risk of misconnection
- Gain values of sensor array stored in EP

Accuracy of Results

- Calibration values stored in EP
- Motor ID imbedded in EP

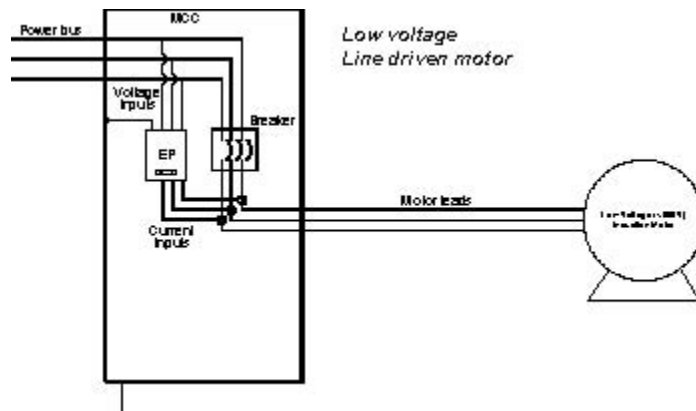

- 1) For medium and high voltage motors, Voltage Inputs are to be connected to the PTs the following way: a) Three phases are to be connected to the two hot secondaries (120V typical) and to the ground, respectively. b) Ground of the PTs secondary has to be connected to the ground input of the EP. 2) For medium and high voltage motors, the CT donuts are to monitor the secondary of the CTs (5A typical) in the MCC. 3) For monitoring of VFD motors, the electrical connections are to be made between the motor and the output of the VFD. 4) In any connection above, the EP-MCC cable is to be connected to the DB 25 of the EP. The other end of the EP-MCC-Cable

